

TEST REPORT Nº / INFORME DE ENSAYO Nº CIMAE56-202310311300R01



T/ +34 986 118 888
 W/ www.cimalab.com
 E/ cimalab@cimalab.com
 C/ Parque Empresarial Terciario Porto do Molle
 Rúa das Pontes nº 19 CP: 36350, Nigrán (Pontevedra) SPAIN

TEST OF STRENGTH OF THE SEAT ANCHORAGE AND THE ADJUSTMENT, LOCKING AND DISPLACEMENT SYSTEMS.

UN Regulation No. 17 10 series of amendments.

ENSAYO DE RESISTENCIA DEL ANCLAJE DEL ASIENTO Y LOS SISTEMAS DE REGULACIÓN, ENCLAVAMIENTO Y DESPLAZAMIENTO.

Reglamento No. 17 de NU serie 10 de enmiendas.

Date of issue / Fecha de emisión:

23/11/2023

**Performed by /
Realizado por:**

**Authorized by /
Autorizado por:**

Diego Acevedo Iglesias

Marcos Barreira Lamas

**Test Engineer
Ingeniero de Ensayos**

**Technical Director
Director Técnico**

The changes are marked with "|" at the right side of the report.

Los cambios son marcados con "|" en negrita en el lateral derecho del informe.



Report emitted and signed digitally by Diego Acevedo Iglesias and Marcos Barreira Lamas.
 This report is available on <http://cve.cimalab.com> with Electronic Verification Code CIMAE56-202310311300R01

The results refer only to the sample under study / Los resultados hacen referencia únicamente a la muestra de estudio.

Total or partial copy of this document is prohibited without written authorization of CIMALab® / Queda prohibida la reproducción total o parcial del presente documento sin autorización expresa de CIMALab®.

N.A.: Not applicable / No aplica.

Interpretation of results: see remarks paragraph / Interpretación de resultados: ver sección de observaciones.

CIMALab® is a registered trademark of Quantum Innovative SL, CIF: B27725225

Parque Empresarial Terciario Porto do Molle, Rúa das Pontes nº19 CP: 36350, Nigrán (Pontevedra) SPAIN +34 986 118 888 www.cimalab.com

TEST REPORT Nº / INFORME DE ENSAYO Nº CIMAE56-202310311300R01

TEST OF STRENGTH OF THE SEAT ANCHORAGE AND THE ADJUSTMENT, LOCKING AND DISPLACEMENT SYSTEMS.

UN Regulation No. 17 10 series of amendments.

**ENSAYO DE RESISTENCIA DEL ANCLAJE DEL ASIENTO Y LOS SISTEMAS DE REGULACIÓN,
ENCLAVAMIENTO Y DESPLAZAMIENTO.****Reglamento No. 17 de NU serie 10 de enmiendas.****I. GENERAL INFORMATION / INFORMACIÓN GENERAL****1. APPLICANT AND MANUFACTURER DATA / DATOS DEL PETICIONARIO Y DEL FABRICANTE****1.1 Applicant / Peticionario**

Name / Nombre: CTA S.r.l.
Address / Dirección: Via Groenlandia, 23
00071 Pomezia
RM - ITALIA

1.2 STU manufacturer / Fabricante de la UTI

Name / Nombre: CTA S.r.l.
Address / Dirección: Via Groenlandia, 23 - 00071 Pomezia (RM) ITALIA

2. STU DATA / DATOS DE LA UTI

Brand / Marca: CTA srl
Type / Tipo: N.A.
**Vehicle categories on which
the device may be installed** M1



The results refer only to the sample under study / Los resultados hacen referencia únicamente a la muestra de estudio.

Total or partial copy of this document is prohibited without written authorization of CIMALab[®] / Queda prohibida la reproducción total o parcial del presente documento sin autorización expresa de CIMALab[®].

N.A.: Not applicable / No aplica.

Interpretation of results: see remarks paragraph / Interpretación de resultados: ver sección de observaciones.

CIMALab[®] is a registered trademark of Quantum Innovative SL, CIF: B27725225

Parque Empresarial Terciario Porto do Molle, Rúa das Pontes nº19 CP: 36350, Nigrán (Pontevedra) SPAIN +34 986 118 888 www.cimalab.com

TEST REPORT Nº / INFORME DE ENSAYO Nº CIMAE56-202310311300R01

TEST OF STRENGTH OF THE SEAT ANCHORAGE AND THE ADJUSTMENT, LOCKING AND DISPLACEMENT SYSTEMS.**UN Regulation No. 17 10 series of amendments.****ENSAYO DE RESISTENCIA DEL ANCLAJE DEL ASIENTO Y LOS SISTEMAS DE REGULACIÓN, ENCLAVAMIENTO Y DESPLAZAMIENTO.****Reglamento No. 17 de NU serie 10 de enmiendas.****Test date / Fecha del ensayo:**

31/10/2023

Test place / Lugar de ensayo:Quantum Innovative, S.L. (CIMALab)
P.E. Terciario Porto do Molle,
Rúa das Pontes Nº 19, Nigrán
36350, Pontevedra (SPAIN)**Sample number / Número de muestra:**

202310311300 - Seat with hand brake adaptation plate.

202311021200 - Seat without hand brake adaptation plate.

Test method / Método de ensayo:**Test of strength of the seat anchorage and the adjustment, locking and displacement systems. /****Ensayo de resistencia del anclaje del asiento y los sistemas de regulación, enclavamiento y desplazamiento.****II. REGULATIONS / NORMATIVA**

- **UN Regulation No. 17 10 series of amendments.**
- **Reglamento No. 17 de NU serie 10 de enmiendas.**



The results refer only to the sample under study / Los resultados hacen referencia únicamente a la muestra de estudio.

Total or partial copy of this document is prohibited without written authorization of CIMALab® / Queda prohibida la reproducción total o parcial del presente documento sin autorización expresa de CIMALab®.

N.A.: Not applicable / No aplica.

Interpretation of results: see remarks paragraph / Interpretación de resultados: ver sección de observaciones.

CIMALab® is a registered trademark of Quantum Innovative SL, CIF: B27725225

Parque Empresarial Terciario Porto do Molle, Rúa das Pontes nº19 CP: 36350, Nigrán (Pontevedra) SPAIN +34 986 118 888 www.cimalab.com

TEST REPORT Nº / INFORME DE ENSAYO Nº CIMAE56-202310311300R01

TEST OF STRENGTH OF THE SEAT ANCHORAGE AND THE ADJUSTMENT, LOCKING AND DISPLACEMENT SYSTEMS.

UN Regulation No. 17 10 series of amendments.

ENSAYO DE RESISTENCIA DEL ANCLAJE DEL ASIENTO Y LOS SISTEMAS DE REGULACIÓN, ENCLAVAMIENTO Y DESPLAZAMIENTO.

Reglamento No. 17 de NU serie 10 de enmiendas.

III. MEASURING EQUIPMENT USED / EQUIPOS DE MEDIDA UTILIZADOS

DEVICE	EQUIPO	CODE / CÓDIGO
Accelerometer	Acelerómetro	ELE007
Accelerometer	Acelerómetro	ELE008

IV. PREVIOUS CONDITIONS / CONDICIONES PREVIAS

- Application of a longitudinal horizontal acceleration concerning to UN Regulation No. 17 10 series of amendments. paragraph 6.3.1.

Aplicación de una aceleración longitudinal horizontal de acuerdo a Reglamento No. 17 de NU serie 10 de enmiendas. punto 6.3.1.

- Requirements: / Requisitos:

Acceleration: / Aceleración:	≥ 20 g
Time: / Tiempo:	≥ 30 ms

The seat and its parts are adjusted and locked as prescribed in paragraphs 6.1.1. and 6.3.4. of applied Regulation. / El asiento y sus partes están reguladas y enclavadas como se describe en los puntos 6.1.1 y 6.3.4.



The results refer only to the sample under study / Los resultados hacen referencia únicamente a la muestra de estudio.

Total or partial copy of this document is prohibited without written authorization of CIMALab® / Queda prohibida la reproducción total o parcial del presente documento sin autorización expresa de CIMALab®.

N.A.: Not applicable / No aplica.

Interpretation of results: see remarks paragraph / Interpretación de resultados: ver sección de observaciones.

TEST REPORT Nº / INFORME DE ENSAYO Nº CIMAE56-202310311300R01

TEST OF STRENGTH OF THE SEAT ANCHORAGE AND THE ADJUSTMENT, LOCKING AND DISPLACEMENT SYSTEMS.

UN Regulation No. 17 10 series of amendments.

ENSAYO DE RESISTENCIA DEL ANCLAJE DEL ASIENTO Y LOS SISTEMAS DE REGULACIÓN, ENCLAVAMIENTO Y DESPLAZAMIENTO.**Reglamento No. 17 de NU serie 10 de enmiendas.****V. RESULTS / RESULTADOS****Tested samples. / Muestras sometidas a ensayo.**

The results refer only to the sample under study / Los resultados hacen referencia únicamente a la muestra de estudio.

Total or partial copy of this document is prohibited without written authorization of CIMALab[®] / Queda prohibida la reproducción total o parcial del presente documento sin autorización expresa de CIMALab[®].

N.A.: Not applicable / No aplica.

Interpretation of results: see remarks paragraph / Interpretación de resultados: ver sección de observaciones.

CIMALab[®] is a registered trademark of Quantum Innovative SL, CIF: B27725225

Parque Empresarial Terciario Porto do Molle, Rúa das Pontes nº19 CP: 36350, Nigrán (Pontevedra) SPAIN +34 986 118 888 www.cimalab.com

TEST REPORT Nº / INFORME DE ENSAYO Nº CIMAE56-202310311300R01

TEST OF STRENGTH OF THE SEAT ANCHORAGE AND THE ADJUSTMENT, LOCKING AND DISPLACEMENT SYSTEMS.

UN Regulation No. 17 10 series of amendments.

ENSAYO DE RESISTENCIA DEL ANCLAJE DEL ASIENTO Y LOS SISTEMAS DE REGULACIÓN, ENCLAVAMIENTO Y DESPLAZAMIENTO.

Reglamento No. 17 de NU serie 10 de enmiendas.

5.1. Frontal collision. / Colisión frontal.

5.1.1 202310311300 - Seat with hand brake adaptation plate.

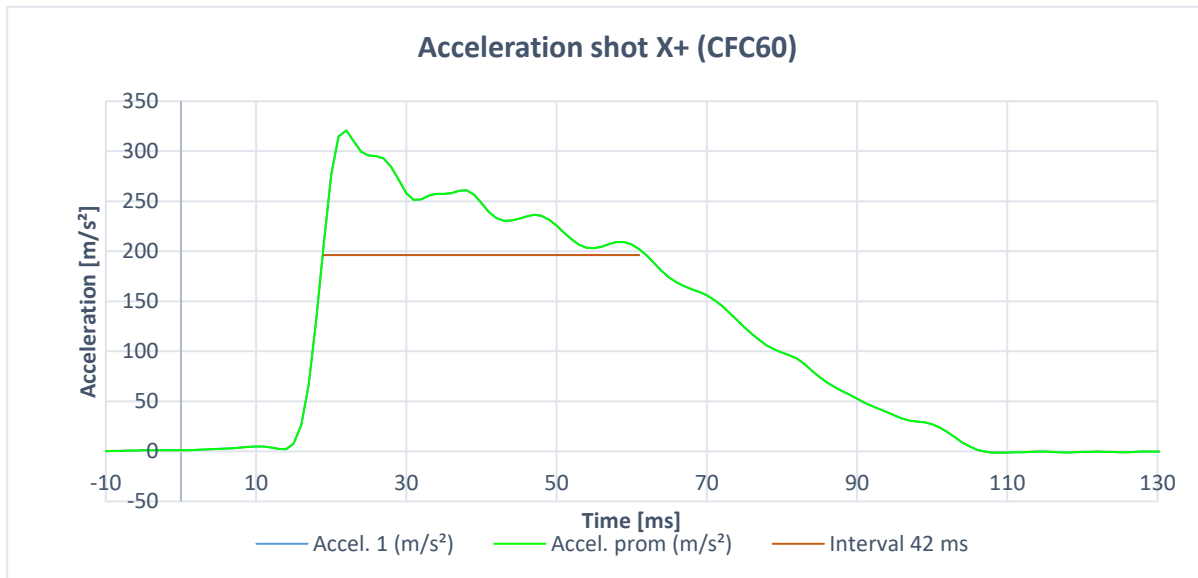

Time with an acceleration not less than 20 g. / Tiempo con una aceleración no inferior a 20g.

42 ms

5.1.2 202311021200 - Seat without hand brake adaptation plate.

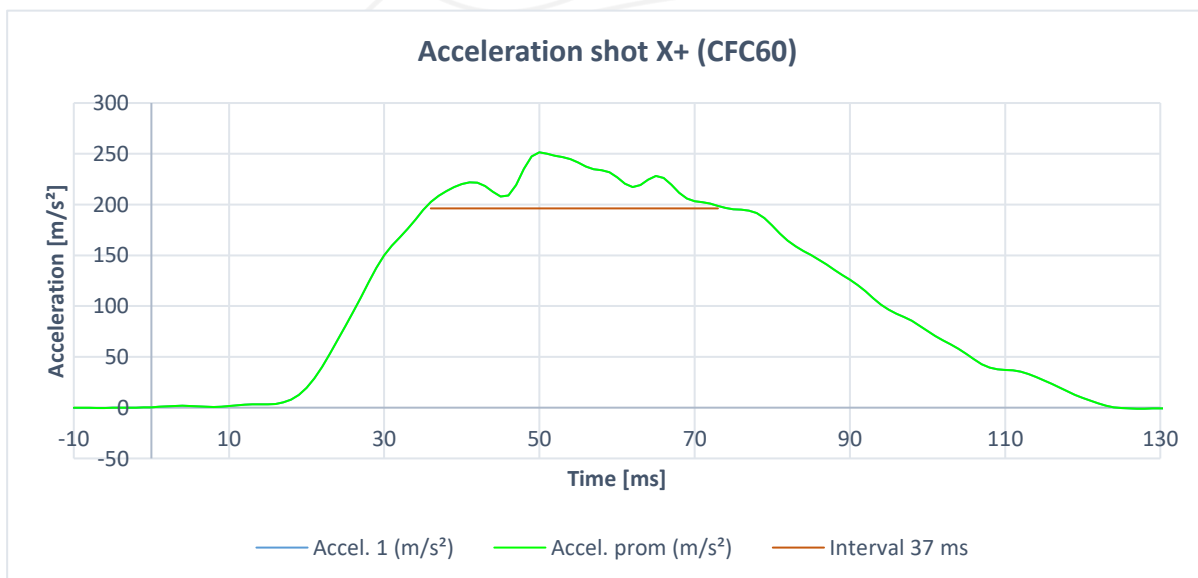

Time with an acceleration not less than 20 g. / Tiempo con una aceleración no inferior a 20g.

37 ms



The results refer only to the sample under study / Los resultados hacen referencia únicamente a la muestra de estudio.

Total or partial copy of this document is prohibited without written authorization of CIMALab[®] / Queda prohibida la reproducción total o parcial del presente documento sin autorización expresa de CIMALab[®].

N.A.: Not applicable / No aplica.

Interpretation of results: see remarks paragraph / Interpretación de resultados: ver sección de observaciones.

CIMALab[®] is a registered trademark of Quantum Innovative SL, CIF: B27725225

Parque Empresarial Terciario Porto do Molle, Rúa das Pontes nº19 CP: 36350, Nigrán (Pontevedra) SPAIN +34 986 118 888 www.cimalab.com

TEST REPORT Nº / INFORME DE ENSAYO Nº CIMAE56-202310311300R01

TEST OF STRENGTH OF THE SEAT ANCHORAGE AND THE ADJUSTMENT, LOCKING AND DISPLACEMENT SYSTEMS.

UN Regulation No. 17 10 series of amendments.

ENSAYO DE RESISTENCIA DEL ANCLAJE DEL ASIENTO Y LOS SISTEMAS DE REGULACIÓN, ENCLAVAMIENTO Y DESPLAZAMIENTO.

Reglamento No. 17 de NU serie 10 de enmiendas.

5.2. Rear collision. / Colisión por alcance.

5.2.1 202310311300 - Seat with hand brake adaptation plate.

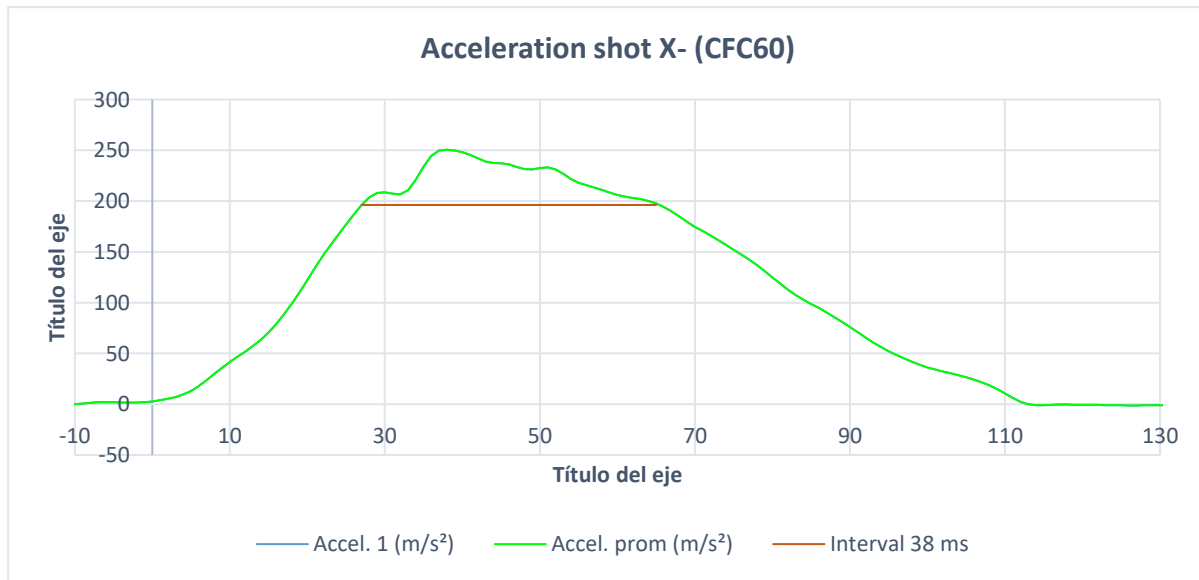

Time with an acceleration not less than 20g. / Tiempo con una aceleración no inferior a 20g.

38 ms

5.2.2 202311021200 - Seat without hand brake adaptation plate.

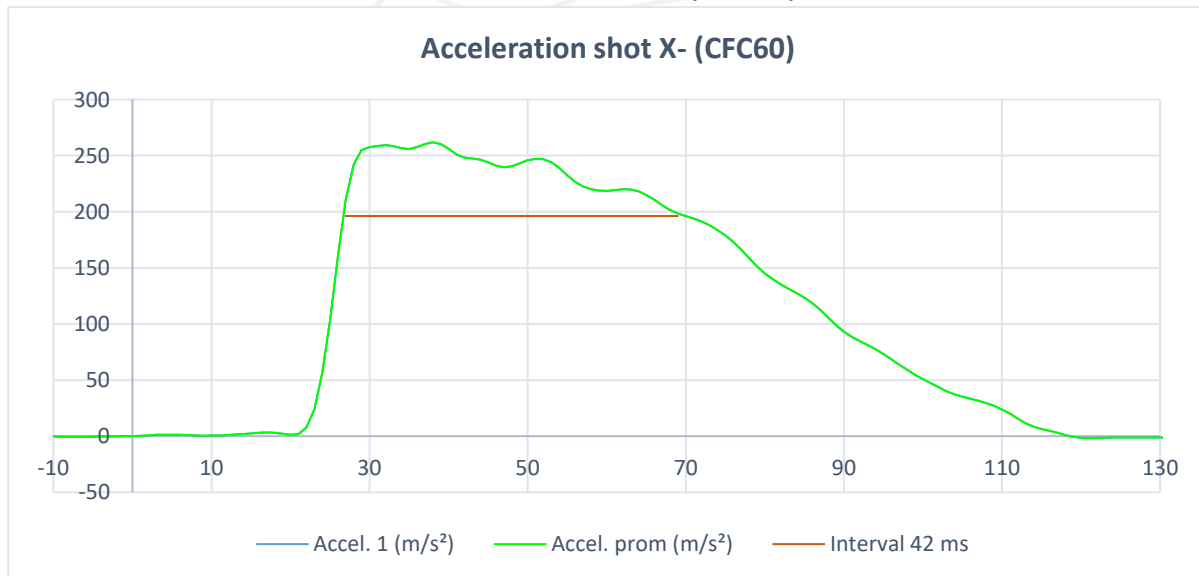

Time with an acceleration not less than 20g. / Tiempo con una aceleración no inferior a 20g.

42 ms



The results refer only to the sample under study / Los resultados hacen referencia únicamente a la muestra de estudio.

Total or partial copy of this document is prohibited without written authorization of CIMALab[®] / Queda prohibida la reproducción total o parcial del presente documento sin autorización expresa de CIMALab[®].

N.A.: Not applicable / No aplica.

Interpretation of results: see remarks paragraph / Interpretación de resultados: ver sección de observaciones.

CIMALab[®] is a registered trademark of Quantum Innovative SL, CIF: B27725225

Parque Empresarial Terciario Porto do Molle, Rúa das Pontes nº19 CP: 36350, Nigrán (Pontevedra) SPAIN +34 986 118 888 www.cimalab.com

TEST REPORT Nº / INFORME DE ENSAYO Nº CIMAE56-202310311300R01

TEST OF STRENGTH OF THE SEAT ANCHORAGE AND THE ADJUSTMENT, LOCKING AND DISPLACEMENT SYSTEMS.

UN Regulation No. 17 10 series of amendments.

**ENSAYO DE RESISTENCIA DEL ANCLAJE DEL ASIENTO Y LOS SISTEMAS DE REGULACIÓN,
ENCLAVAMIENTO Y DESPLAZAMIENTO.****Reglamento No. 17 de NU serie 10 de enmiendas.****VI. CONFORMITY / CONFORMIDAD**

The seat anchorage and the adjustment, locking and displacement systems comply with paragraph 5.2.5, specifically for paragraph 6.3 of UN Regulation 17R10.

El anclaje del asiento y los sistemas de regulación, enclavamiento y desplazamiento cumplen con el punto 5.2.5, y en particular para el punto 6.3 del Reglamento de NU 17R10.



The results refer only to the sample under study / Los resultados hacen referencia únicamente a la muestra de estudio.

Total or partial copy of this document is prohibited without written authorization of CIMALab® / Queda prohibida la reproducción total o parcial del presente documento sin autorización expresa de CIMALab®.

N.A.: Not applicable / No aplica.

Interpretation of results: see remarks paragraph / Interpretación de resultados: ver sección de observaciones.

CIMALab® is a registered trademark of Quantum Innovative SL, CIF: B27725225

Parque Empresarial Terciario Porto do Molle, Rúa das Pontes nº19 CP: 36350, Nigrán (Pontevedra) SPAIN +34 986 118 888 www.cimalab.com

TEST REPORT Nº / INFORME DE ENSAYO Nº CIMAE56-202310311300R01

TEST OF STRENGTH OF THE SEAT ANCHORAGE AND THE ADJUSTMENT, LOCKING AND DISPLACEMENT SYSTEMS.

UN Regulation No. 17 10 series of amendments.

ENSAYO DE RESISTENCIA DEL ANCLAJE DEL ASIENTO Y LOS SISTEMAS DE REGULACIÓN, ENCLAVAMIENTO Y DESPLAZAMIENTO.**Reglamento No. 17 de NU serie 10 de enmiendas.****VII. REMARKS / OBSERVACIONES****The tested samples are selected as the worst case according to manufacturer's document "016-23/CTA-R3"***Las muestras ensayadas son seleccionadas como worst case de acuerdo al documento del fabricante "016-23/CTA-R3".*

9PG0070000V01
9PG0070001V01
9PG0090000V01
9PG0098000V01
9PG0085800V01
9PG0116200V01
9PG0131510V01

This test report is completed with the attached manufacturer's drawings, 8 pages.*Este informe de ensayo es completado con los planos del fabricante adjuntos, 8 páginas.***RELATIVE TO MEASUREMENTS / RELATIVO A LAS MEDIDAS:****The significant figures of the values are according to the measuring instrument***Las cifras significativas de los resultados son acordes a las medidas de los equipos.***The declaration of compliance is made following the criteria established in document ILAC-G8: 9/2019, taking a binary Statement for Simple Acceptance Rule, with a result limited to «pass» or «fail» ./**
*declaración de cumplimiento se realiza siguiendo el criterio establecido en el documento ILAC-G8:9/2019 tomando una regla de decisión binaria para una regla de aceptación simple, con un resultado limitado a dos opciones «pasa» o «no pasa».***In case the magnitude is bounded by a lower limit in the normalized method, the rule will be followed:***En caso de que la magnitud se encuentre acotada por un límite inferior en el método normalizado, se seguirá la regla:*

$$\text{Measure} \geq \text{limit}$$

In case the magnitude is bounded by an upper limit in the standardized method, the rule will be followed:*En caso de que la magnitud se encuentre acotada por un límite superior en el método*

$$\text{Measure} \leq \text{limit}$$

*The results refer only to the sample under study / Los resultados hacen referencia únicamente a la muestra de estudio.**Total or partial copy of this document is prohibited without written authorization of CIMALab® / Queda prohibida la reproducción total o parcial del presente documento sin autorización expresa de CIMALab®.**N.A.: Not applicable / No aplica.**Interpretation of results: see remarks paragraph / Interpretación de resultados: ver sección de observaciones.***CIMALab® is a registered trademark of Quantum Innovative SL, CIF: B27725225**

Parque Empresarial Terciario Porto do Molle, Rúa das Pontes nº19 CP: 36350, Nigrán (Pontevedra) SPAIN +34 986 118 888 www.cimalab.com

TEST REPORT N° / INFORME DE ENSAYO N° CIMAE56-202310311300R01

TEST OF STRENGTH OF THE SEAT ANCHORAGE AND THE ADJUSTMENT, LOCKING AND DISPLACEMENT SYSTEMS.

UN Regulation No. 17 10 series of amendments.

ENSAYO DE RESISTENCIA DEL ANCLAJE DEL ASIENTO Y LOS SISTEMAS DE REGULACIÓN, ENCLAVAMIENTO Y DESPLAZAMIENTO.

Reglamento No. 17 de NU serie 10 de enmiendas.

VIII. PICTURES / IMÁGENES



Seat 1 / Asiento 1

The results refer only to the sample under study / Los resultados hacen referencia únicamente a la muestra de estudio.

Total or partial copy of this document is prohibited without written authorization of CIMALab[®] / Queda prohibida la reproducción total o parcial del presente documento sin autorización expresa de CIMALab[®].

N.A.: Not applicable / No aplica.

Interpretation of results: see remarks paragraph / Interpretación de resultados: ver sección de observaciones.

CIMALab[®] is a registered trademark of Quantum Innovative SL, CIF: B27725225

Parque Empresarial Terciario Porto do Molle, Rúa das Pontes nº19 CP: 36350, Nigrán (Pontevedra) SPAIN +34 986 118 888 www.cimalab.com



TEST REPORT Nº / INFORME DE ENSAYO Nº CIMAE56-202310311300R01

TEST OF STRENGTH OF THE SEAT ANCHORAGE AND THE ADJUSTMENT, LOCKING AND DISPLACEMENT SYSTEMS.

UN Regulation No. 17 10 series of amendments.

ENSAYO DE RESISTENCIA DEL ANCLAJE DEL ASIENTO Y LOS SISTEMAS DE REGULACIÓN, ENCLAVAMIENTO Y DESPLAZAMIENTO.

Reglamento No. 17 de NU serie 10 de enmiendas.



Seat 2. / Asiento 2.



The results refer only to the sample under study / Los resultados hacen referencia únicamente a la muestra de estudio.

Total or partial copy of this document is prohibited without written authorization of CIMALab[®] / Queda prohibida la reproducción total o parcial del presente documento sin autorización expresa de CIMALab[®].

N.A.: Not applicable / No aplica.

Interpretation of results: see remarks paragraph / Interpretación de resultados: ver sección de observaciones.

CIMALab[®] is a registered trademark of Quantum Innovative SL, CIF: B27725225

Parque Empresarial Terciario Porto do Molle, Rúa das Pontes nº19 CP: 36350, Nigrán (Pontevedra) SPAIN +34 986 118 888 www.cimalab.com

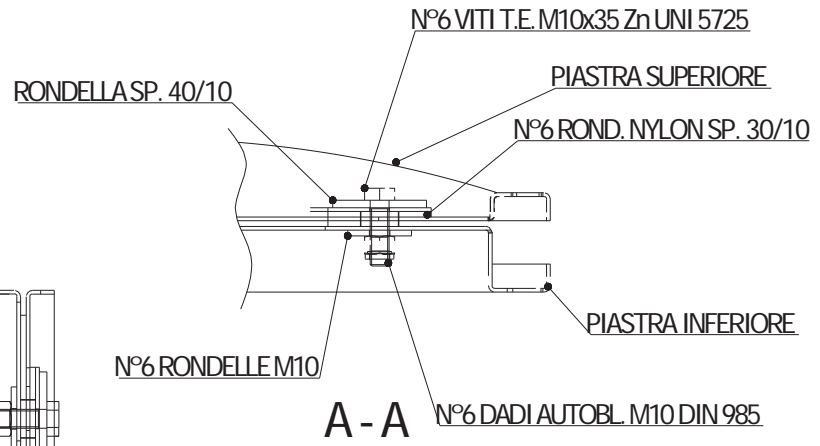
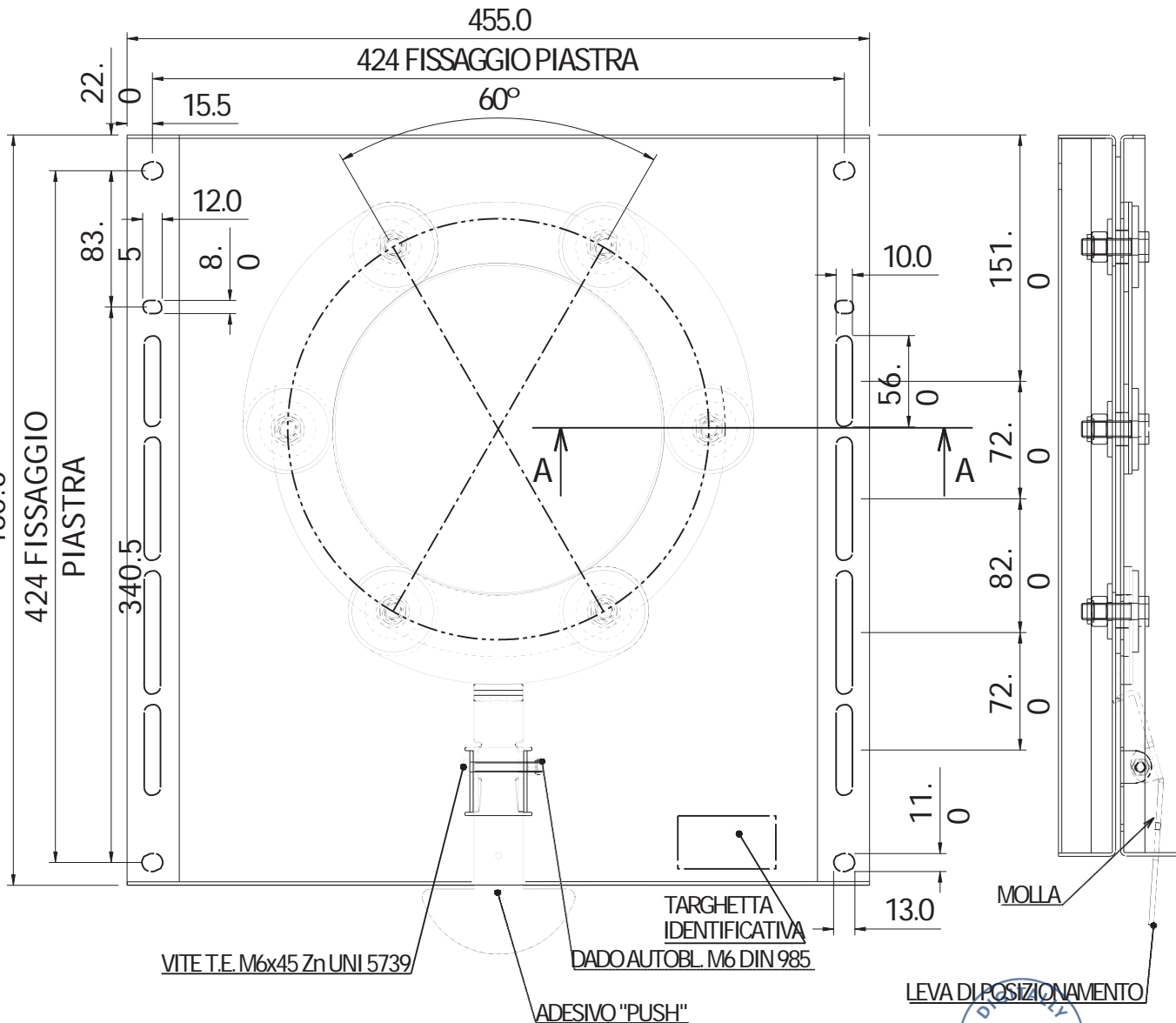

N.B.
SPESSORE LAMIERA UTILIZZATA 20/10

REV.	DESCRIZIONE	ESEGUITO	VERIFICATO	DATA
MASSA	MATERIALE	TOLLERANZE UNI EN 22768-1 ECCETTO DOVE INDICATO - TIPO:		
Kg 8.8	VEDI FOGLIO DI LAVORAZIONE	FINE <input type="checkbox"/>	MEDIA <input type="checkbox"/>	GROSSOLANA <input type="checkbox"/>
TRATTAMENTO CHIMICO SUPERFICIALE	VERNICIATURA	MOLTO GROSSOLANA <input checked="" type="checkbox"/>		
Sp. -	Sp. -	Sp. -		
VEDI FOGLIO DI LAVORAZIONE				
		DISEGNATO	DATA	
		U.M.F.	28/03/2012	
		CONTROLLATO	DATA	
		C.B.	28/03/2012	
DESCRIZIONE		SCALA	1:2	
PIASTRA GIREVOLE MERCEDES SPRINTER		FOGLIO	DI	
VOLKSWAGEN CRAFTER 1996-2005		DI	1	
P/N	REV.	FORMATO	RISERVA SU QUESTO SPACIO PER CAD O MODIFICHE MANUALI	
00700	0	A2		
PROPRIETA' CTA S.r.l. - RIPRODUZIONE VIETATA - DIRITTI TUTELATI A TERMINE DI LEGGE				



PN	DESCRIPTION	MASS
9PG0070001V01	PIASTRA GREVOLE MERCEDES SPRINT 2018- 2019	-

RAW/MATERIAL	QTY	NOTE
-	-	-

OP/SEQ	DESCRIPTION	NOTE
1	ASSEMBLAGGIO	
2	-	
3	-	
4	-	
NEXT	IMBALLAGGIO	

Annex to CIMAE56-202310311300R01 - 2/8

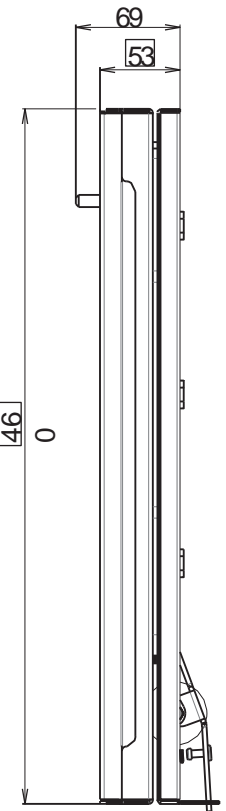
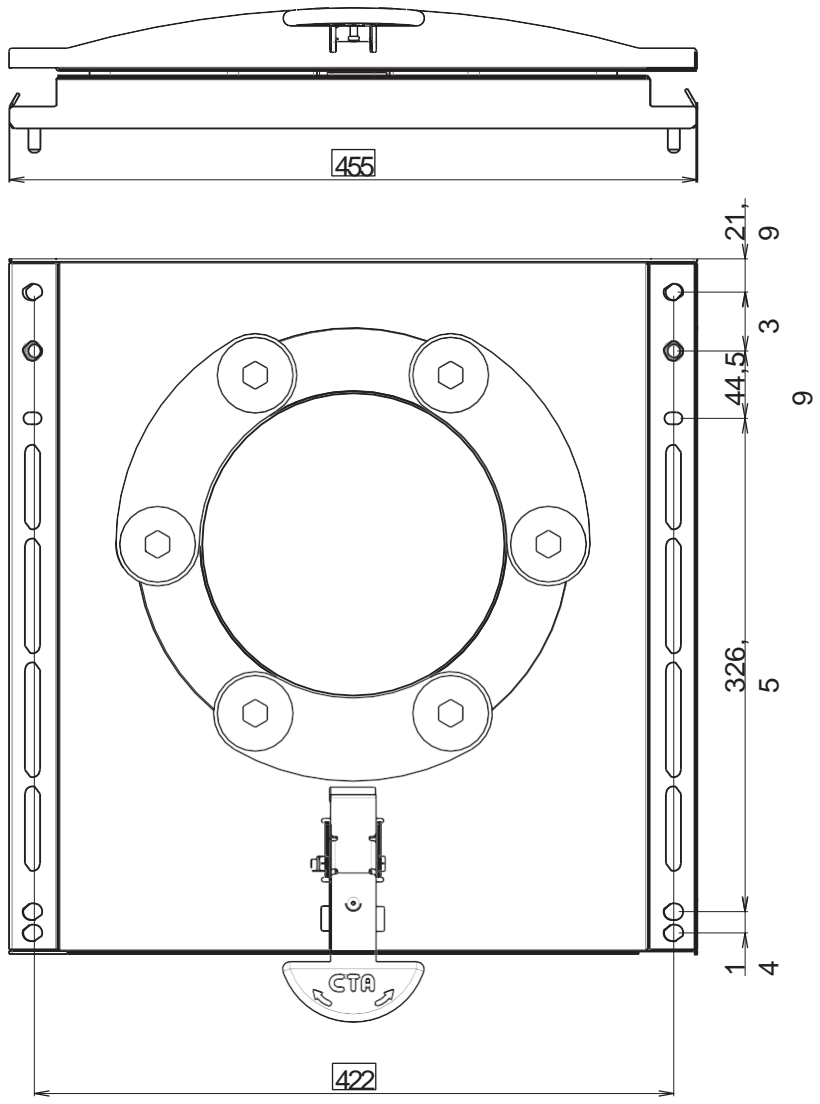
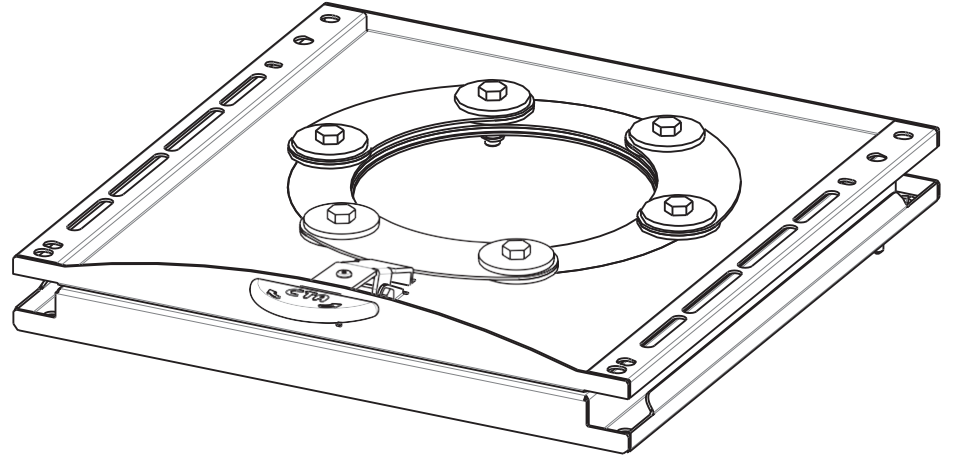

COPPIA DI SERRAGGIO 30Nm

REV.	DESCRIPTION	DONE	VERIFIED	DATE
17	1VT0086600Z32 VITE T.E.M10x35 Zn UNI 5739	6		
16	1MP0024300X00 RONDELLA IN NYLON INT. 20,5 ØEST. 55 SP:3mm	6		
15	1VT0024700Z32 RONDELLA Ø INT. 10,20 EST. 50 SP:4	6		
14	1VT0051300Z32 RONDELLA PIANA M10x40 SP:2,5 ZINCATA EXTRALARGE	6		
13	1VT0021300X00 DADO M10 AUTOBLOCCANTE DIN 982	6		
12	1VT0068300X00 BOCCELLA	6		
11	2PG0021501P06 MEZZALUNA ZINCATA	3		
10	2PG0070001V10 ASSEMBE PIASTRINO - FERNO	2		
9	1VT0086900Z32 BULLONE T.E.M6x45 ZINCATO FILETTATURA INTEGRALE UNI 5739	1		
8	2PG0070001P01 PIASTRA SUPERIORE	1		
7	2PG0070001P02 PIASTRA INFERIORE	1		
6	1VT0011700X32 M.C.LLA 1,5x8,7x35 Zn	1		
5	2PG0066500Z32 MANIGLIA PIASTRA GREVOLE	1		
4	1VT0023200X00 DADO M6 AUTOBLOCCANTE DIN 982	1		
3	2PG0021500P08 LAMIERA TAGLIATA (ANELLO CENTRALE)	1		
2	2PG0021500P05 LAMIERA TAGLIATA	1		
1	1MP0021500P09 FLANGIA	1		

POS	PN	DESCRIPTION	QTY	PREVIEW
2	MODIFICATO PIASTRA SUPERIORE POS 8 E IL PARTICOLARE 1VT0068300X00 SOSTITUISCE L'1VT0024300X00 POS.12		MC	MU
08/03/2023				

REV.	DESCRIPTION	DONE	VERIFIED	DATE
2	MODIFICATO PIASTRA SUPERIORE POS 8 E IL PARTICOLARE 1VT0068300X00 SOSTITUISCE L'1VT0024300X00 POS.12	MC	MU	08/03/2023

MASS	MATERIAL	UNI EN 22768-1 TOLERANCE EXCEPT FROM WHERE INDICATED. LAKE
8,8 kg-	-	f <input type="checkbox"/> m <input checked="" type="checkbox"/> [<input type="checkbox"/> v <input type="checkbox"/>
SUPERFICIAL CHEMICAL TREATMENT PAINTING		NOVE FILE - REVISIONE
9PG0070001V01_R2		

DRAWN U.Mr.	DATE	10/03/2023
VERIFIED C.B.	DATE	10/03/2023
APPROVED D.B.	DATE	10/03/2023

DESCRIPTION	PIASTRA GREVOLE MERCEDES SPRINT 2018 - 2019
P/N	9PG0070001V01
SCALE	-
PAPER OF	2
FORMAT	A2
CAD DRAWING MANUAL CHANGES OR MODIFICATION NOT ADMITTED	



PN	DESCRIPTION	MASS
9PG0085800V01	PIASTRA GIREVOLE VOLKSWAGEN TRANSPORTER	
RAVMATERIAL	QTY	NOTE
OP SEQ	DESCRIPTION	NOTE
1	ASSEMBLAGGIO	
2		
3		
4		
NEXT		

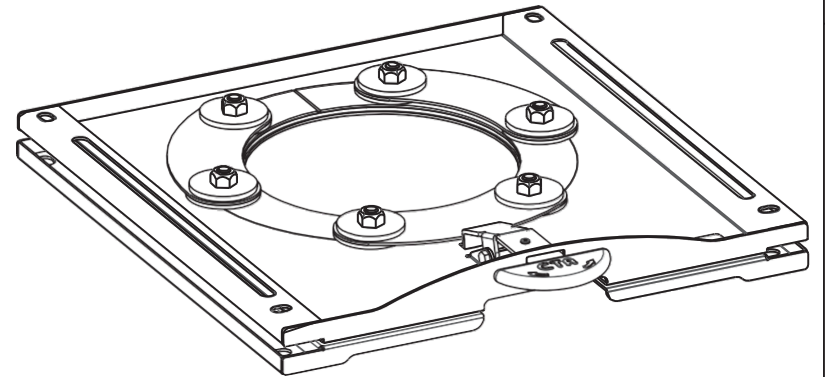
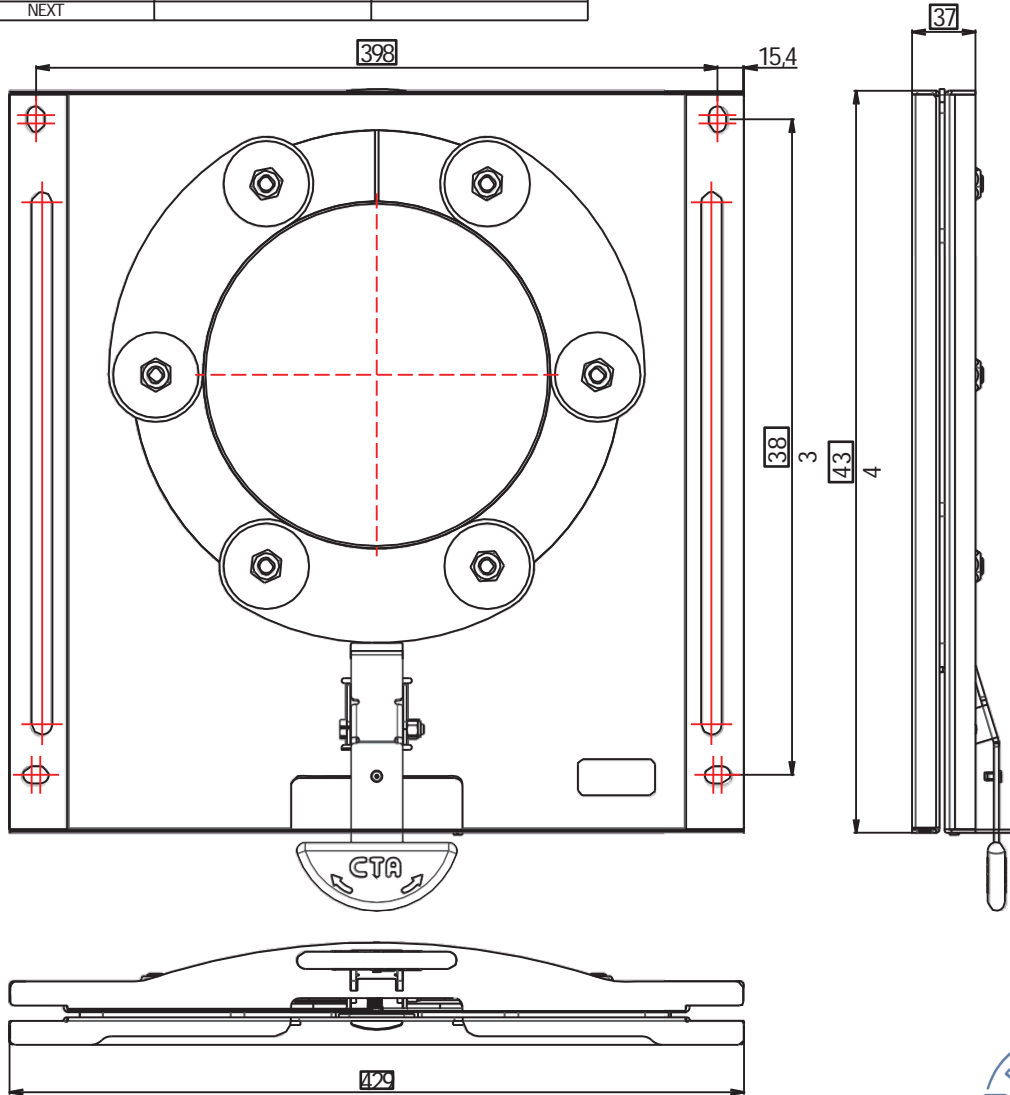

3	SCSTITUTIAE INVERTITOSISTEMA DIMONTAGGIO DELLA VITE M10x35 UNI 5739 CON VITE M10x35 UNI 7380	UM:	UM:	25/10/2023
2	MODIFICATOPIASTRA SUPERIORE POS:7	MC	MU	10/03/2023
REV.	DESCRIPTION	DONE	VERIFIED	DATE
MASS	MATERIAL	UNI EN 22768-1 TOLERANCE EXCEPT FROM WHERE INDICATED, LAKE:		
	SEE PROD. FILES	f <input type="checkbox"/>	m <input checked="" type="checkbox"/>	[<input type="checkbox"/> V <input checked="" type="checkbox"/>
SUPERFICIAL CHEMICAL TREATMENT	PAINTING	NOME FILE - REVISIONE		
		9PG0085800V01_R3		
		DRAWN	DATE	25/10/2023
		REVISIONED	DATE	25/10/2023
		APPROVED	DATE	25/10/2023
DESCRIPTION		SCALE		
PIASTRA GIREVOLE VOLKSWAGEN TRANSPORTER		PAPER OF		
P7N		FORMA1		
9PG0085800V01		A2	CAD DRAWING MANUAL CHANGES OR MODIFICATION NOT ADMITTED	
CTA S.r.l. - PROPERTY - NO REPRODUCTION - FIXED TERM LAWRIGHTS				



PN	DESCRIPTION	MASS
9PG0090000V01	PIASTRA GIREVOLE FORD TRANSIT	
RAVMATERIAL	QTY	NOTE
OP SEQ	DESCRIPTION	NOTE
1	ASSEMBLAGGIO	
2		
3		
4		
NEXT		

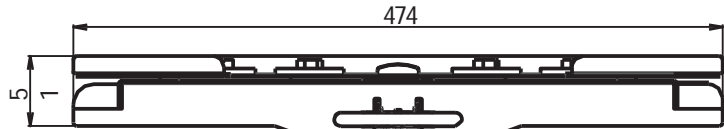

A-A

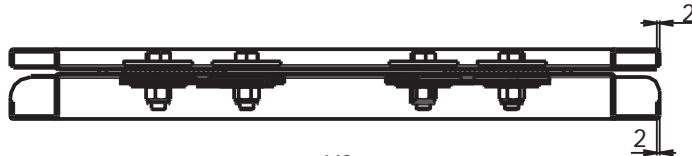

442

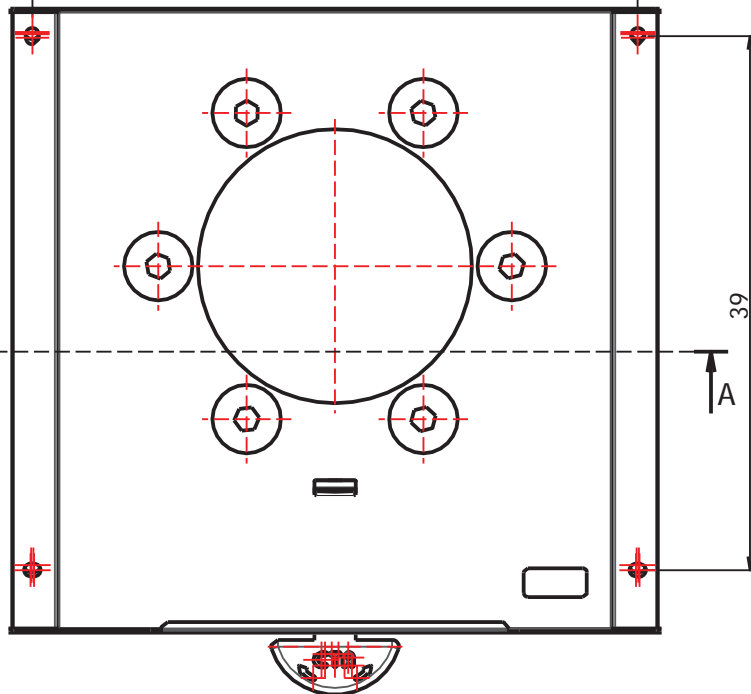

A

COPPIA DI SERRAGGIO 30 Nm

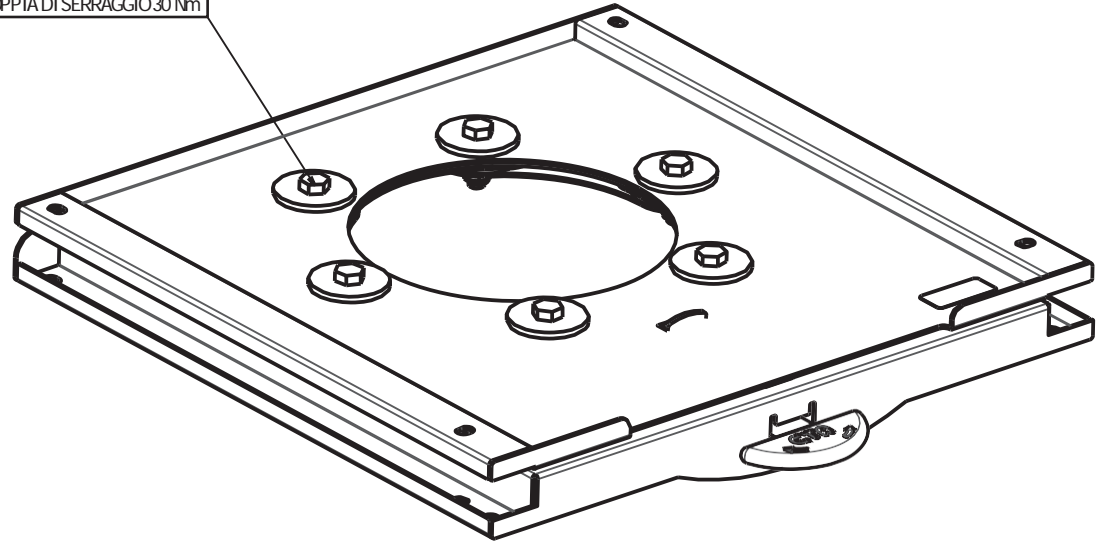

45

0

7



SERIES SWIVEL PLATE 9PG0090000V01

08	Inserito sistema seeger			13/07/2022
01	AGGIUNTO FOGLIO 2 E AGGIORNATE LE VISTE.	MCaliachia	M.Ubaldi	29/04/2022
REV.	DESCRIPTION	DONE	VERIFIED	DATE
MASS	MATERIAL	UNI EN 22768-1 TOLERANCE EXCEPT FROM WHERE INDICATED, LAKE:		
		f	m	c
SUPERFICIAL CHEMICAL TREATMENT	PAINTING	NOME FILE - REVISIONE		
		9PG0090000V01_R8		
DRAWN		DATE	DATE	
M.C.		14/09/2020	14/09/2020	
C.B.		14/09/2020	14/09/2020	
APPROVED		DATE	DATE	
U.M.		14/09/2020	14/09/2020	
DESCRIPTION		SCALE		
PIASTRA GIREVOLE FORD TRANSIT		1		
P/N		PAPER		
9PG0090000V01		OF		
		FORMAT		
		A2		
CAD DRAWING MANUAL CHANGES OR MODIFICATION NOT ADMITTED				
CIA S.r.l. - PROPERTY - NO REPRODUCTION - FIXED TERM LAWR RIGHTS				

PN	DESCRIPTION	MASS
9PG0098000V01	PIASTRA GIREVOLE FORD TRANSIT	
RAVMATERIAL	QTY	NOTE
OP SEQ	DESCRIPTION	NOTE
1	ASSEMBLAGGIO	
2		
3		
4		
NEXT		

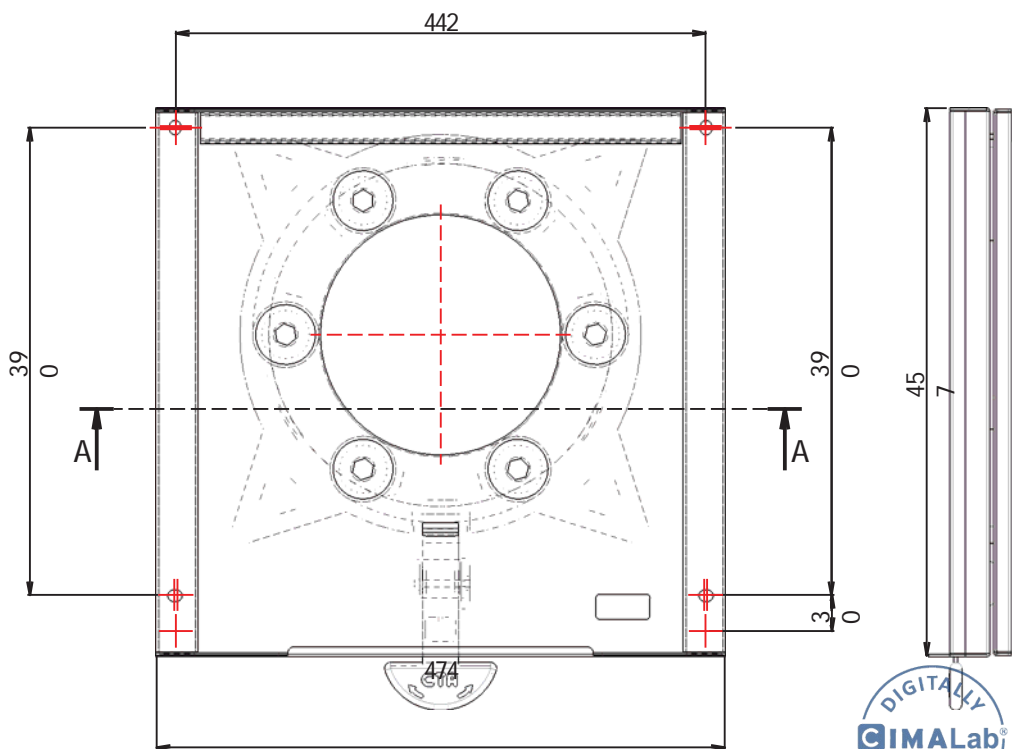
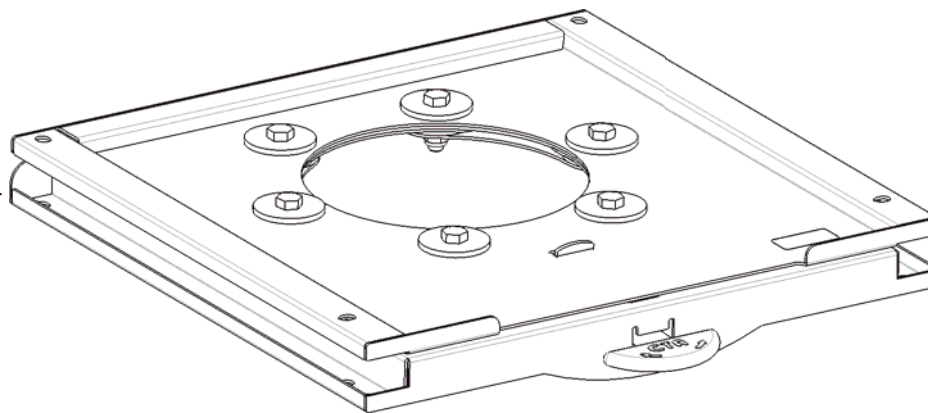
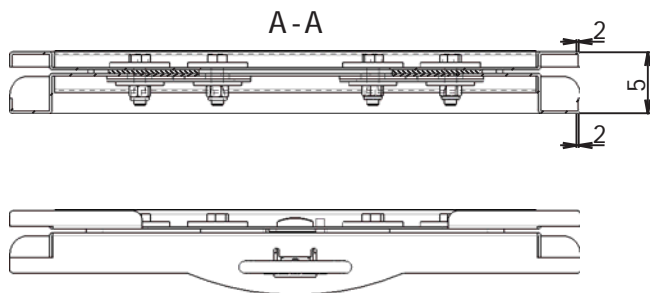

SERIES SWVEL PLATE 9PG0098000V01

3	Inserito sistema seeger			13/07/2022
2	AGGIUNTA PAGINA 2, AGGIORNATA DISTINTA EVISTE DISEGNO E MODELLO	M. CALICCHIA		
REV.	DESCRIPTION	DONE	VERIFIED	DATE
MASS	MATERIAL	UNI EN 22768-1 TOLERANCE EXCEPT FROM WHERE INDICATED, LAKE:		
		f <input type="checkbox"/>	m <input checked="" type="checkbox"/>	[<input type="checkbox"/> V <input checked="" type="checkbox"/>
SUPERFICIAL CHEMICAL TREATMENT PAINTING		NOME FILE - REVISIONE		
		9PG0098000V01-R3		
		DRAWN	DATE	
		M.C.	27/01/2020	
		CB.	27/01/2020	
		APPROVED	DATE	
		UM.	27/01/2020	
DESCRIPTION		SCALE		
PIASTRA GIREVOLE FORD TRANSIT		1		
P/N	FORMA	CAD DRAWING MANUAL CHANGES OR MODIFICATION NOT ADMITTED		
9PG0098000V01	A2			
CIA S.r.l. - PROPERTY - NO REPRODUCTION - FIXED TERM LAWR RIGHTS				



PN	DESCRIPTION	MASS
9PG0116200V01	PIASTRA GIREVOLE IVECO DAILY 2019	
RAWMATERIAL	QTY	NOTE
CP SEQ	DESCRIPTION	NOTE
1	ASSEMBLAGGIO	
2		
3		
4		
NEXT		

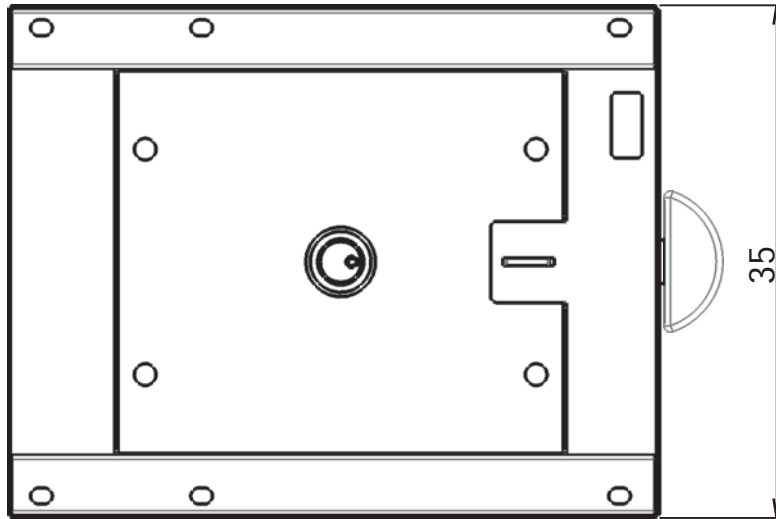
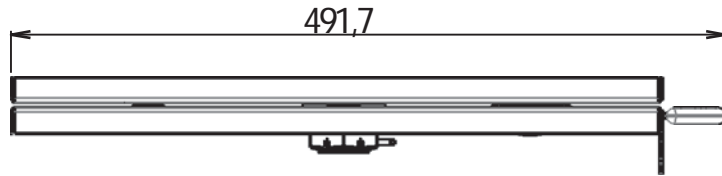
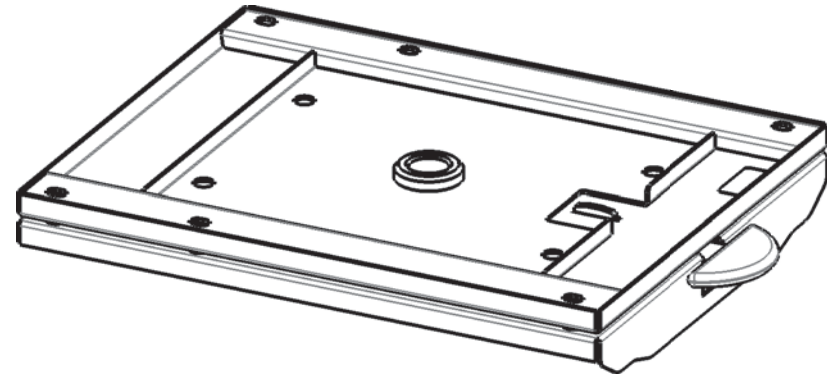

4	1MP0024400X10	TASSELLO IN NYLON	6	
9	1ET0116200X00	ETICHETTA AUTOADESIVA IN POLIESTERE	1	
8	1VT0105100X00	COPIGLIA 3,2x20 INOX	1	
7	2PG0116200P10	RONDELLA M36 NYLON 3mm	1	
12	2PG0116200P09	RONDELLA M36 NYLON 2mm	1	
11	CPGRM01-07	DADO A CORONA M 36x1,5	1	
3	2PG0116200W40	ASSIEME DI SALDATURA PIASTRA SUPERIORE	1	
2	2PG0116200W30	ASSIEME SALDATURA PIASTRA INFERIORE	1	
1	2PG00058PLZ32	ASSIEME MANIGLIA	1	
POS	PN	DESCRIPTION	QTY	PREVIEW

REV.	DESCRIPTION	DONE	VERIFIED	DATE

MASS	MATERIAL	UNI EN 22768-1 TOLERANCE EXCEPT FROM WHERE INDICATED, LAKE:
		f <input type="checkbox"/> m <input checked="" type="checkbox"/> [<input type="checkbox"/> V <input type="checkbox"/>

SUPERFICIAL CHEMICAL TREATMENT	PAINTING	NOTE FILE - REVISIONE
		9PG0116200V01

CTA S.r.l.	DRAWN LP	DATE	14/01/2020
	VERIFIED CB	DATE	14/01/2020
	APPROVED U.Mr.	DATE	14/01/2020

DESCRIPTION	SCALE	PAPER OF	FORMAT
PIASTRA GIREVOLE IVECO DAILY 2019	-	1	A3

P/N	9PG0116200V01	CAD DRAWING MANUAL CHANGES OR MODIFICATION NOT ADMITTED
-----	---------------	---



PN	DESCRIPTION	MASS
9PG0131512V01	PIASTRA GIREVOLE RENAULT TRAFICGUIDATORE BIANCA	
RAVMATERIAL	QTY	NOTE
OP SEQ	DESCRIPTION	NOTE
1	ASSEMBLAGGIO	
2		
3		
4		
NEXT		

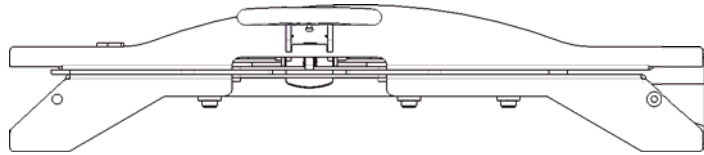

COPIA DI SERRAGGIO 30 Nm

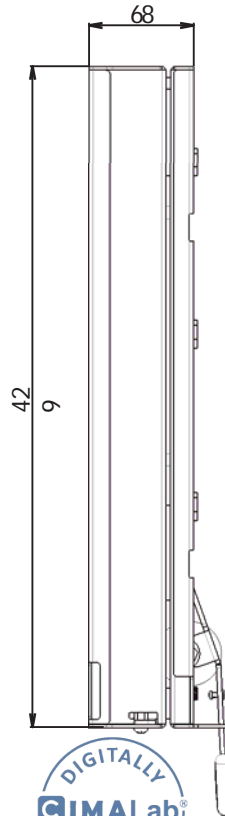
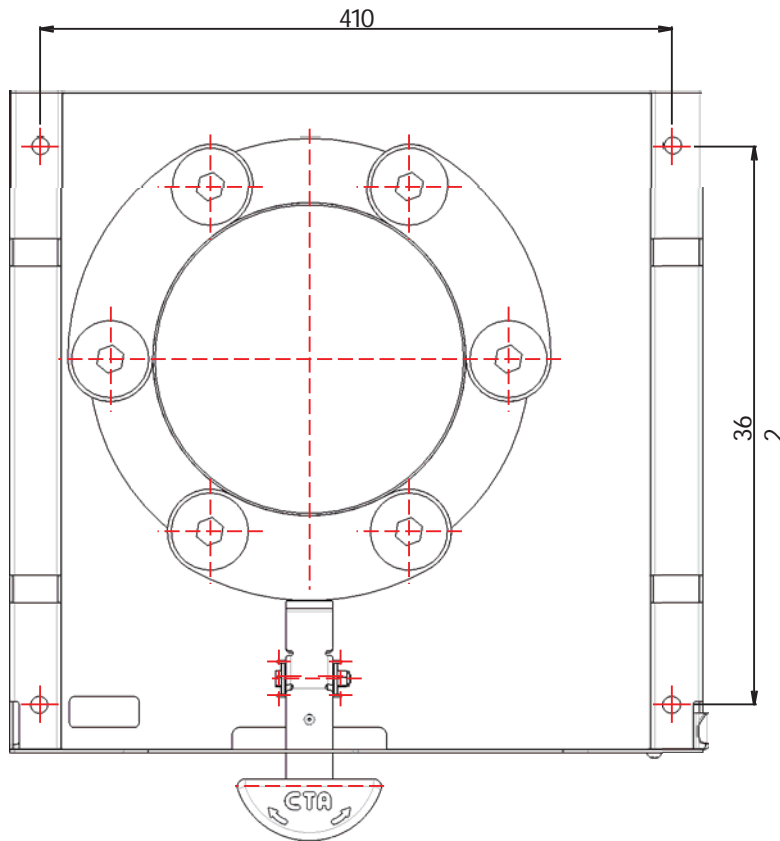
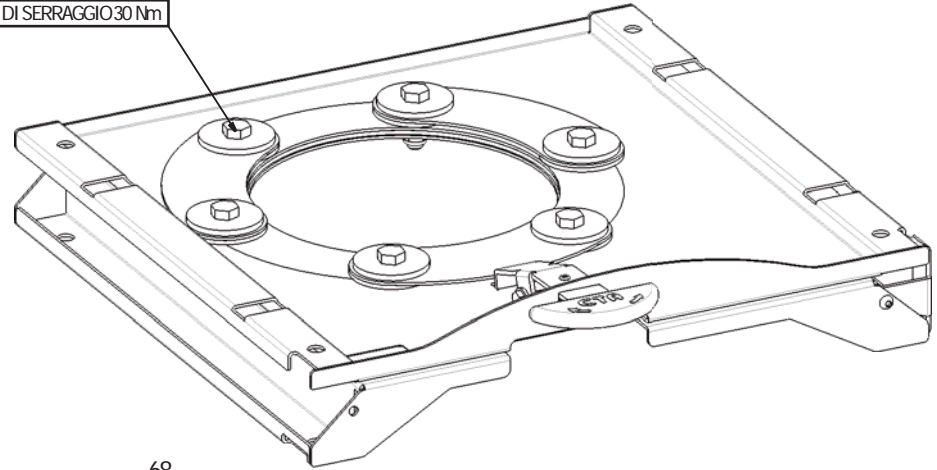

AVAILABLE FOR:
 RENAULT TRAFIC X82-X83-FIAT TALENTO
 OPEL VIVARO-NISSAN NV300

REV.	DESCRIPTION	DONE	VERIFIED	DATE
MASS	MATERIAL	UNI EN 22768-1 TOLERANCE EXCEPT FROM WHERE INDICATED, LAKE:		
		f	m	[] V
SUPERFICIAL CHEMICAL TREATMENT	PAINTING	NOME FILE - REVISIONE		
		9PG0131512V01		
 DRAWN F.P. CHECKED C.B. APPROVED U.M. DATE 07/04/2023 DATE 07/04/2023 DATE 07/04/2023		SCALE		
		PAPER	1	
		OF	2	
DESCRIPTION PIASTRA GIREVOLE RENAULT TRAFICGUIDATORE BIANCA P/N 9PG0131512V01		FORMAT	A2	CAD DRAWING MANUAL CHANGES OR MODIFICATION NOT ADMITTED
CTA S.r.l. - PROPERTY - NO REPRODUCTION - FIXED TERM LAW RIGHTS				



PN	DESCRIPTION	MASS
9PG0131513V01	PIASTRA GIREVOLE RENAULT TRAFIC PASSEGGERO BIANCA	
RAVMATERIAL	QTY	NOTE
OP SEQ	DESCRIPTION	NOTE
1	ASSEMBLAGGIO	
2		
3		
4		
NEXT		

COPPIA DI SERRAGGIO 30 Nm

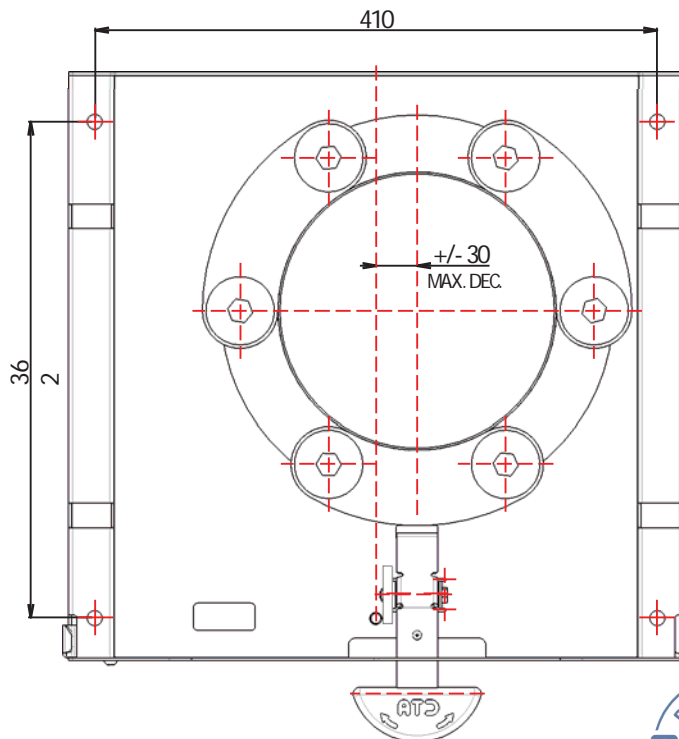
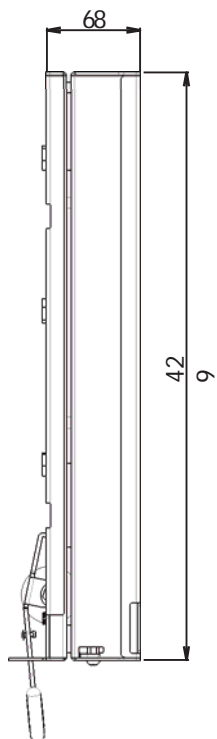
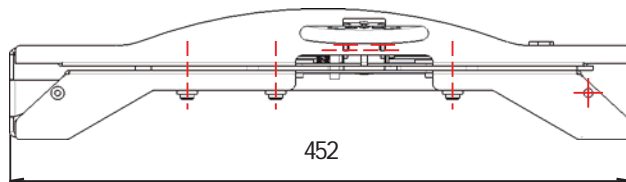
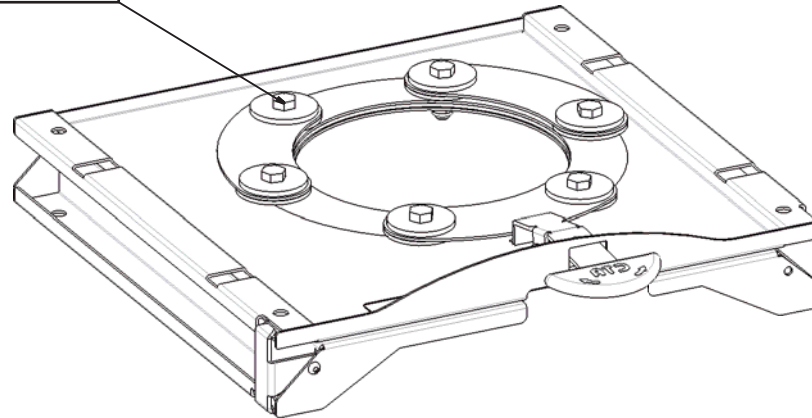

03		FP	MU.	
02		FP	MU.	
01		FP	MU.	
REV.	DESCRIPTION	DONE	VERIFIED	DATE
MASS	MATERIAL	UNI EN 22768-1 TOLERANCE EXCEPT FROM WHERE INDICATED, LAKE:		
		<input checked="" type="checkbox"/> f	<input checked="" type="checkbox"/> m	<input type="checkbox"/> [] <input type="checkbox"/> V
SUPERFICIAL CHEMICAL TREATMENT	PAINTING	NOME FILE - REVISIONE		
		9PG0131513V01		
		DRAWN	DATE	08/07/2022
		F.P.	DATE	07/04/2023
		CB.	DATE	07/04/2023
DESCRIPTION		SCALE		
PIASTRA GIREVOLE RENAULT TRAFIC PASSEGGERO BIANCA		1		
P7/N		FORMAT		
9PG0131513V01		A2	CAD DRAWING MANUAL CHANGES OR MODIFICATION NOT ADMITTED	
GTA S.r.l. - PROPERTY - NO REPRODUCTION - FIXED TERM LAW RIGHTS				

